



CASPTM
Home *PRO*
ELITE



OWNER'S MANUAL

CAUTION: Read manual carefully for proper procedures and operation.

Congratulations

on your purchase of a CASPR Technologies enhanced air and surface disinfection system. This unit is designed to be mounted into a facility HVAC system. Please read and follow all safety warnings and service procedures outlined in this manual. Use only genuine CASPR Technologies replacement parts available from your CASPR Technologies Distributor.

If you have any questions concerning this or any CASPR Technologies product, contact your CASPR Technologies Distributor.

To learn more about the CASPR Medik and other CASPR Technologies products and technologies, please visit our website at

www.casprtech.com.

Table of Contents

Warnings	3
Specifications & Contents.....	4
Setup	5
Installation.....	6-7
Maintenance & Replacement parts (purchased separately):.....	8
Replacing Cell	9
Warranty Information.....	10

IMPORTANT SAFETY INSTRUCTIONS



When using an electrical appliance, basic precautions should always be taken.

READ ALL INSTRUCTIONS BEFORE USING THIS PRODUCT

WARNING!

To reduce the risk of fire, electrical shock, or injury:

- Use only as described in this manual.
- Never operate unit near a heat source, open flame or flammable/combustible fluids.
- Do not operate unit unless all parts (including Cell, & bulb) are properly installed.
- Directly viewing the lamp for an extended period may result in eye damage.
- Do not allow foreign objects to enter the ventilation openings.
- Unit should be powered OFF and Power Cord should be disconnected when Cleaning/Disassembling/ Reassembling/ Servicing.
- **Do not touch NC₂I bulb with bare hands.**

	<p style="text-align: center;"> WARNING</p> <p>WARNING! - UV light in operation. Disconnect unit from power supply before servicing. Failure to follow warnings may result in severe eye damage.</p>
---	---

Specifications

ELECTRICAL: 120-277 VAC

Home Pro Elite - 35W (start-up), 28.3W (Operation)

SIZE: (HxWxD)

Home Pro Elite 9" x 9" x 10.5"

Weight

Home Pro Elite : 3.5 lbs.

Unit Contents

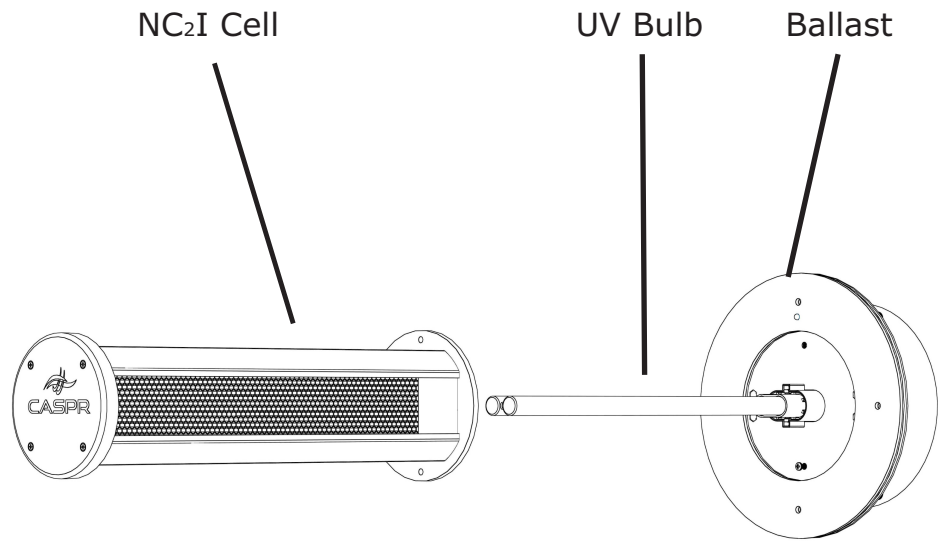

Adhesive Gasket

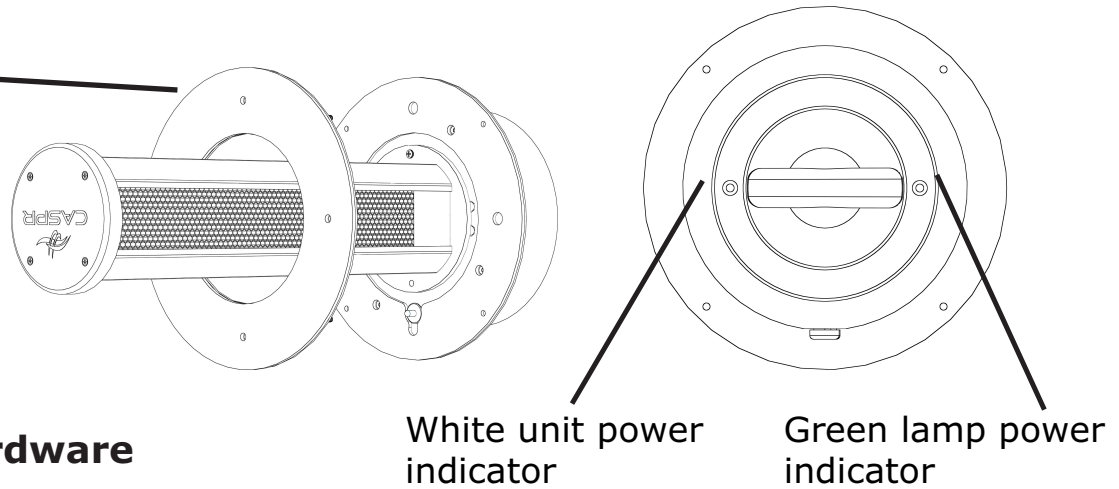

Installation Hardware

- (4) Self-tapping Screws
- (2) Cell Mounting Screws
- (4) Thumb Nuts

Recommended Installation Tools

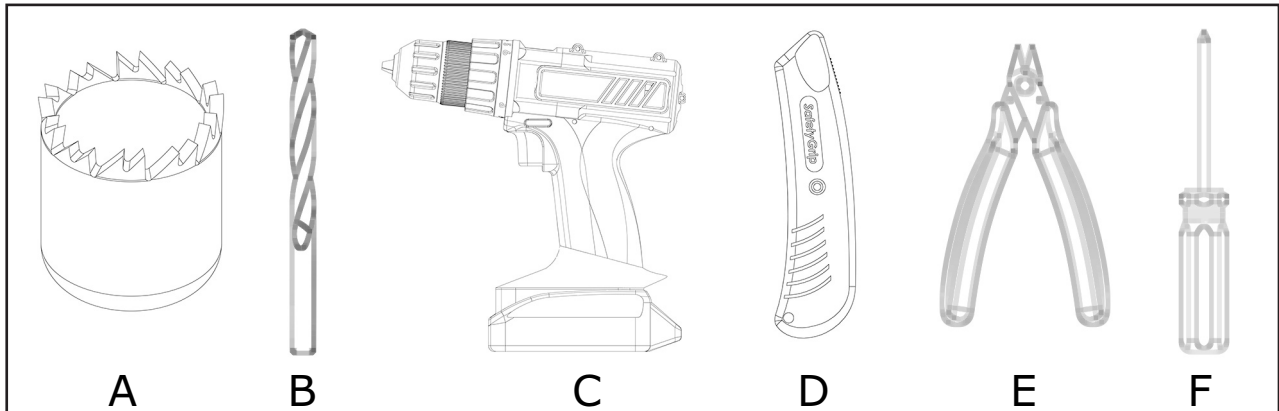

A - 4.5" Hole Saw Bit

D - Utility Knife

B - 3/8" Drill Bit

E - Tin Snips

C - Drill/Power Driver

F - Phillips Head Screwdriver

Installation Requirement

1. Unit may be installed up or down stream of the air handler in the HVAC system as long as it is behind the filter.
2. The ductwork around the installation area should be cleaned and dry to insure proper adhesion of the gasket materials and any tape used.
3. One circular opening, measuring approximately 4.5", will need to be cut into the existing duct work to install the unit properly.

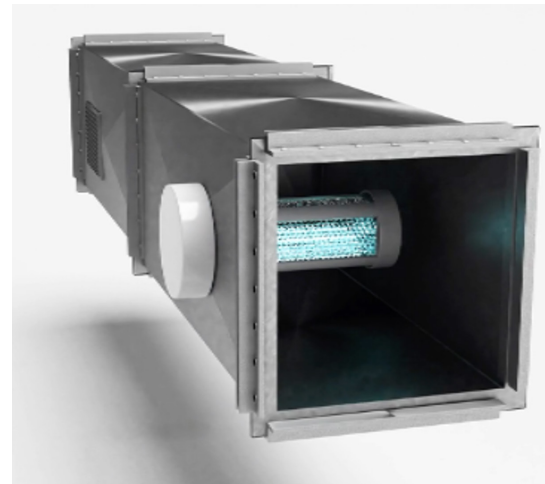

Electrical Requirement

To use the 120V plug, be sure to locate the unit within 9 ft. of a standard 120V grounded outlet. Long term use on an extension cord is not recommended due to safety considerations

Hardwiring Requirements

Permanent wiring of the unit into your HVAC system should be done by a licensed HVAC Installer or Electrical Contractor only.

For 110-277V:

Black = L1, White = Neutral, Green - Ground

Installation

1. Locate a suitable area of the duct to install the CASPR Medik.

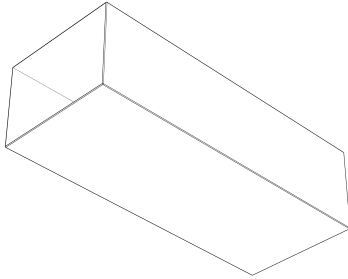

2. If necessary, cut away insulation for your plate to adhere to the duct.

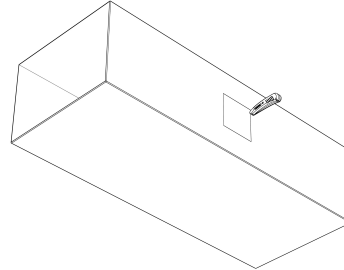

3. Using the Adhesive Gasket Plate, trace the inner hole location onto the duct.

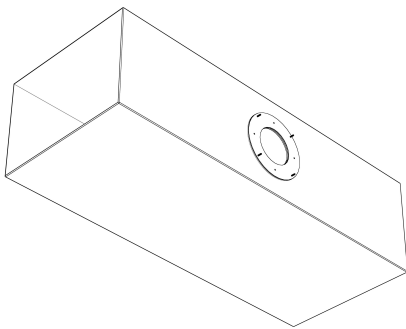

4 Use the 4.5" Hole Saw and Drill to cut out the marked hole.

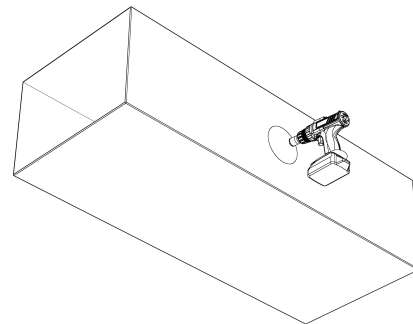

Alternative Installation

4. Drill holes around the outside edges of the previously marked hole but inside the outer holes of the Adhesive Gasket Plate.

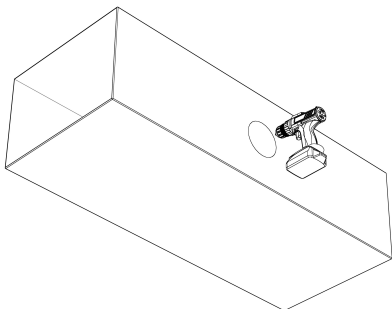

5. Use the Tin Snips to cut out the space around the marked hole.

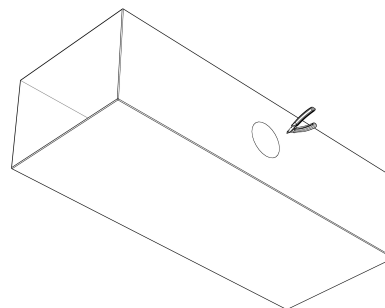

Installation

6. Remove the plastic backing on your Adhesive Gasket Plate.

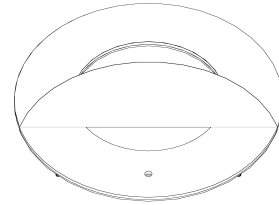

7. Press the Adhesive Gasket Plate onto the duct. Secure with the (4) Self-Tapping Screws.

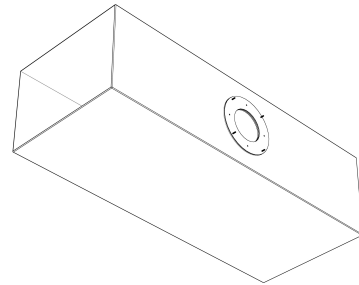

8. Connect the Cell to the Ballast using the two (2) cell mounting screws.

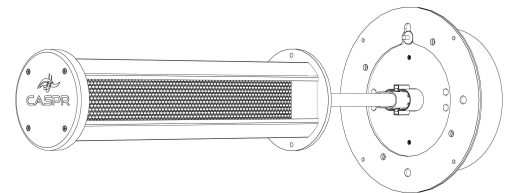

9. Place the unit and cell through the opening and align the four PEM studs. Locking in unit with 4 Thumb Nuts

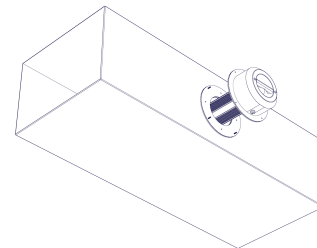

10. Plug the Unit Power Cable Into the receptacle or have a Licensed Electrician or HVAC Installer hardwire the unit directly into the HVAC system

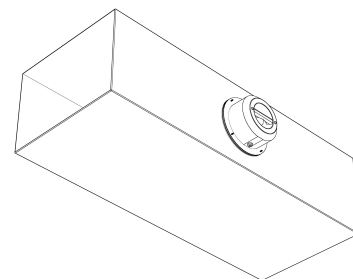

Maintenance / UV Lamp Indicator

Your CASPR HomePro Elite requires no periodic maintenance beyond normal replacement cell and bulb at 18 to 24 months.

Note: Proper Operation

The unit operates properly when the white LED light indicates power, and the green LED light confirms that the lamp is functioning.

Disposal Of The NC2I Cell

Please do not throw the used NC₂I Cells in the garbage.

The special germicidal UV bulb used in the CASPR HomePro Elite contains some insignificant amount of mercury. Contact your local Waste Management Center for a proper disposal procedure.

Replacement Parts

Bulbs:

6" Bulb Part Number: CP-UVCCP-144-4HHOSPL02 1X7315

Cell (which includes 1 bulb):

6" NC₂I Cell Part Number: CASPR Medik 6 Cell 1X7313

Changing the NC₂I Cell

1. Remove the Unit Power Cable from the receptacle or ensure the unit isn't powered.

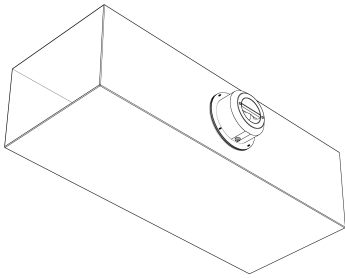

2. Remove the (4) Thumb Nuts and pull the unit away from the mounting plate. Pull the unit from the duct.

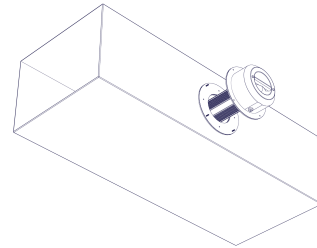

3. Remove the (2) Screws holding the NC₂I Cell in place and remove the NC₂I Cell from the Unit Cover.

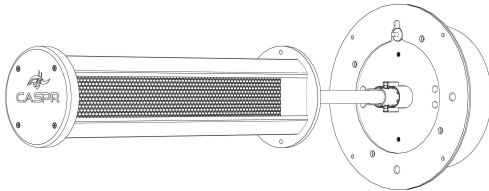

4. Exchange the Old NC₂I Cell with the new NC₂I Cell and replace the (2) Screws that hold it in place.

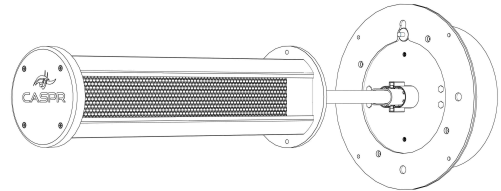

5. Replace the unit in the duct and secure the unit with (4) Thumb Nuts

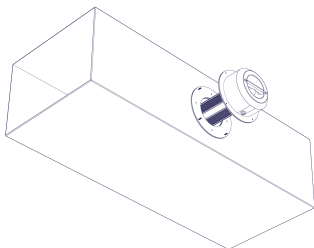

6. Place the Unit Power Cable back into the receptacle or repower your unit.

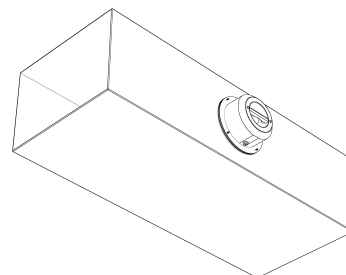

Warranty Information

CASPR TECHNOLOGIES – EXPRESS LIMITED WARRANTY

NDS Sales LLC d/b/a CASPR Technologies (as “Seller”) offers the following Express Limited Warranty to a buying customer (a “Buyer”) of a CASPR product (the “Product”): Seller warrants to Buyer that:

Consumable Components

The components comprised of the UV lamp and cell will be free from defects caused by faulty workmanship or materials for two (2) years from the date of purchase when operated under normal conditions and in accordance with Seller’s recommended use (the “Components Warranty Period”). The UV lamp and cell are consumable components and are not covered beyond the Components Warranty Period, regardless of operating hours or usage.

Power Module Warranty (Limited Lifetime)

The Product’s power module, including the ballast (power supply) and associated electronics (the “Power Module”), is warranted against defects in materials and workmanship for the lifetime of the original installation, subject to the conditions set forth below (the “Limited Lifetime Power Module Warranty”). For purposes of this warranty, the “lifetime of the original installation” means the period during which the Product remains installed at its original installation location by the original Buyer and is supported by Seller as an active product model. Relocation of the Product or transfer of ownership voids this warranty.

Required Condition – Lamp Replacement

The Limited Lifetime Power Module Warranty is expressly conditioned upon proper maintenance of the Product. As a condition of coverage:

- The UV lamp must be replaced every two (2) years, or sooner if failure occurs.
- Failure to replace the UV lamp within the required interval will void the Limited Lifetime Power Module Warranty.
- Proof of timely lamp replacement (including purchase records or service documentation) may be required to validate a Power Module warranty claim.

Registration Requirement

To receive warranty coverage, including coverage under the Limited Lifetime Power Module Warranty, the Product must be registered with Seller within sixty (60) days of installation in accordance with Seller’s warranty registration procedures.

Failure to register the Product within this timeframe will void or limit warranty coverage, including the Limited Lifetime Power Module Warranty. Proof of installation date may be required to validate warranty eligibility. Late registration, if accepted by Seller in its sole discretion, shall not extend the warranty commencement date, which shall be deemed the original installation date.

Disclaimer of Other Warranties

SELLER EXPRESSLY DISCLAIMS ALL OTHER WARRANTIES, WHETHER EXPRESS OR IMPLIED, INCLUDING BUT NOT LIMITED TO ANY IMPLIED WARRANTIES OF MERCHANTABILITY OR FITNESS FOR A PARTICULAR PURPOSE.

Remedy

At its sole discretion, Seller will repair or replace any defective consumable component or Power Module covered under this Express Limited Warranty. Replacement parts may be new or refurbished and will be of equal or better quality and performance.

Any replacement component furnished under this warranty shall be covered only for the remainder of the original applicable warranty period and shall not extend or restart any warranty term. Buyer’s sole and exclusive remedy under this warranty is limited to repair or replacement.

Exclusions

This Express Limited Warranty does not cover damage or failure resulting from:

- Improper or unauthorized installation, alteration, or misuse
- Operation outside Seller’s published environmental or electrical specifications
- Acts of nature, including but not limited to lightning, power surges, flooding, or fire
- Normal wear and tear beyond the applicable warranty periods
- Labor costs associated with removal or reinstallation of the Product or any component
- Use in applications or environments not expressly approved by Seller in writing

Warranty Claims

To obtain warranty service, Buyer must:

- Submit a warranty claim through Seller’s designated warranty process or website
- Provide proof of purchase and installation date
- Provide documentation demonstrating compliance with the required UV lamp replacement schedule for Power Module related claims

Seller reserves the right to inspect the Product or any component prior to approving or denying a warranty claim. Buyer is responsible for shipping the Product or affected component to Seller unless otherwise authorized in writing by Seller.

Limitation of Liability

This Express Limited Warranty does not extend to or cover incidental or consequential damages, including but not limited to downtime costs, loss of use, loss of revenue, or loss of profits.

Sales Through Distributor or Reseller

To the extent the Product is purchased by Buyer from an authorized CASPR distributor or reseller, this Express Limited Warranty passes through to Buyer. No distributor, reseller, or sales representative is authorized to modify, extend, or amend this warranty.

Governing Law

For U.S. applications, product warranties are governed by applicable state and federal laws and may vary from state to state. For Canadian applications, applicable provincial and territorial laws shall apply. In the event of a conflict between this Express Limited Warranty and such laws, the applicable law shall control.



CASPR[™]
TECHNOLOGIES

WWW.CASPRTECH.COM

620 LOTUS DRIVE N
MANDEVILLE, LA 70471
(844) 717-8819